

## BioLite SolarHome 620

SHA1001.R6.IM

### Instruction Manual

Guía de Inicio Rápido

Guide de Démarrage Rapide

Snelstartgids

Schnellstartanleitung

빠른 시작 설명서

Guida Rapida

クイックスタートガイド

Pikaopas

Snabbguide

Hurtigveiledning

快速入门指南

## IN THE BOX

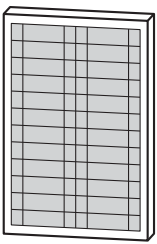

1  
Solar Panel



2  
Control Box with  
Light & Radio

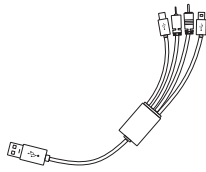

USB Adapter



Wall Screws  
Or Nails

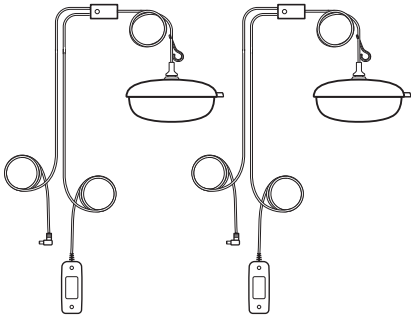

3  
(2) Hanging Lights with Switch

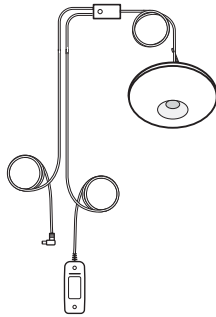

4  
Security Light with  
Motion Detector & Switch

## TEST YOUR SETUP BEFORE ATTACHING SCREWS

Run cords to **Hanging Lights** and **Control Box** to ensure proper length. See diagram and quick tips below for help.

1

Place **Solar Panel** high on roof for direct sunlight.

2

Mount **Control Box** 1.5 meters off the ground in a central location in your home.

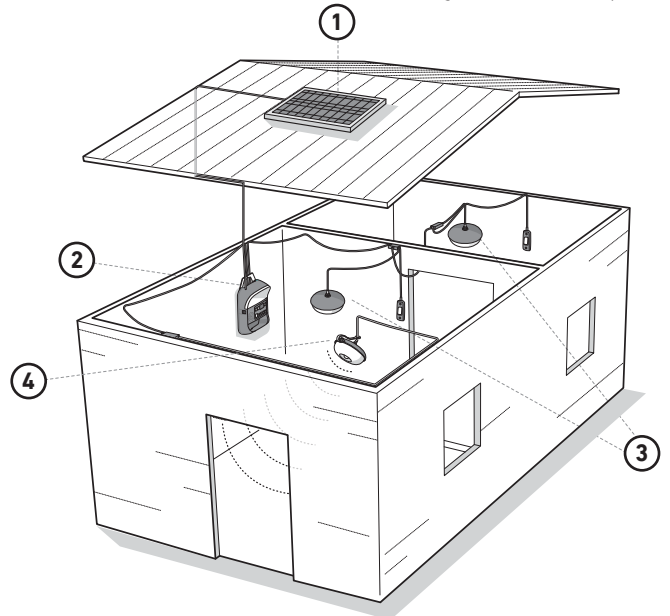

3

Decide which 2 lights will connect directly to the **Control Box**. Your third light will connect via the **Extension Port** located on each light, creating a network of lighting.

4

For security lighting, utilize the **Motion Detector** to turn on light automatically.

# 1 SOLAR PANEL INSTALLATION

## 1.1

To keep panel clean, place **Solar Panel** high on roof and at an angle.

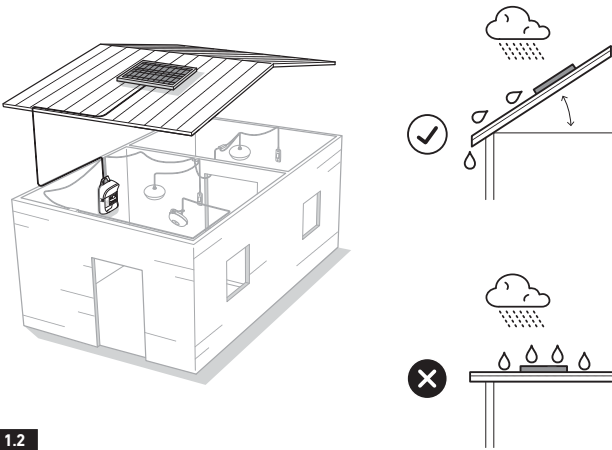

## 1.2

Avoid shadows caused by trees or buildings – this will make less power.

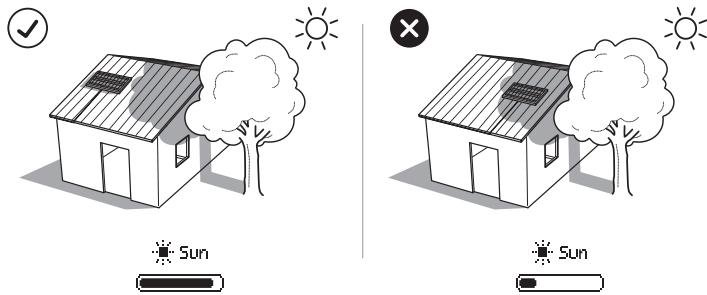

## 1.3

Use a screw or wire to properly install **Solar Panel** on the roof.

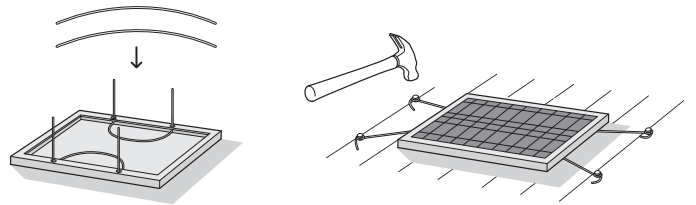

## 1.4

Run cord from **Solar Panel** to location of where **Control Box** will be inside your home.

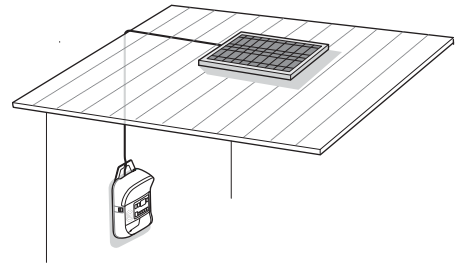

## NOTE

It is okay to leave solar panel on roof when it is raining. Rain will help to keep solar panel free of dust.



## 2 CONTROL BOX INSTALLATION

### 2.1

The **Control Box** features its own light. Turn light **ON** to illuminate area and help with easy installation.

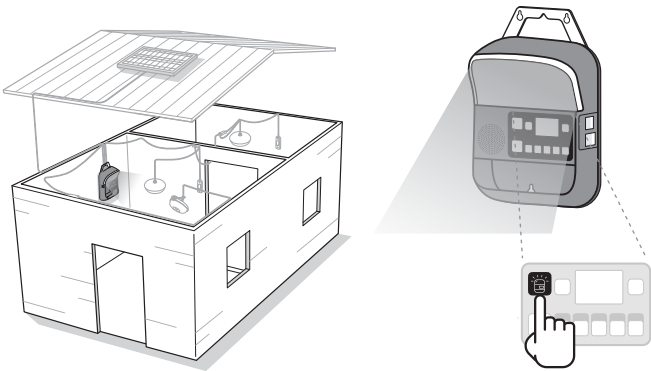

### 2.2

Keep **Control Box** out of reach of children – we recommend installing it 1.5 meters off the ground.

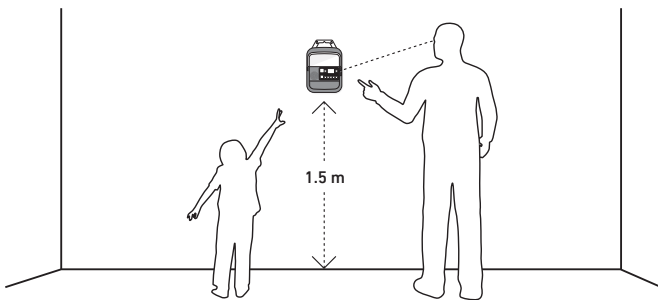

### 2.3

Place 3 screws or nails into wall according to **Control Box** attachment points.

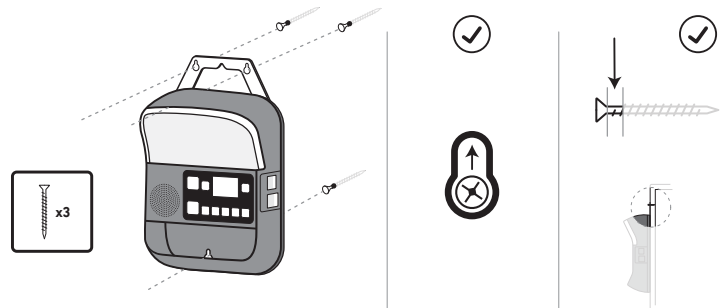

### 2.4

Place **Control Box** over screws and slide down to secure position. Do not tighten screws completely into the wall – this will allow easy removal of **Control Box** for future setup and use.



### NOTE

Keep **Control Box** dry and securely placed to avoid damage to unit.



### 3 HANGING LIGHT INSTALLATION

#### 3.1

The SolarHome 620 includes 3 hanging lights: **2 Hanging Lights** and **1 Security Light with Motion Sensor**. Each light (A) includes a Light Switch (B), Extension Port (C), Hook (D), and Connector (E)

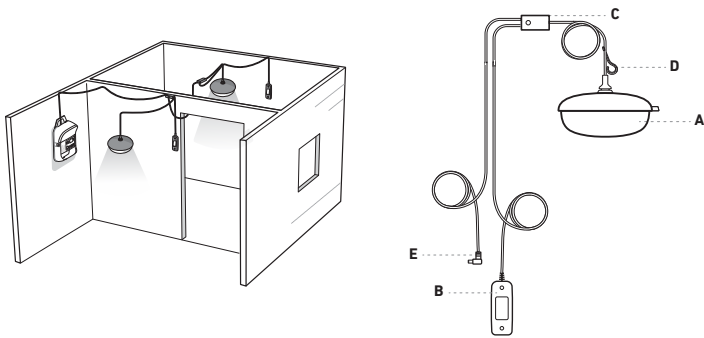

#### 3.2

Connect up to **2 Hanging Lights** directly to **Control Box**. Connect third light via **Extension Port** of previously connected Lights. Lights can be connected in any order.

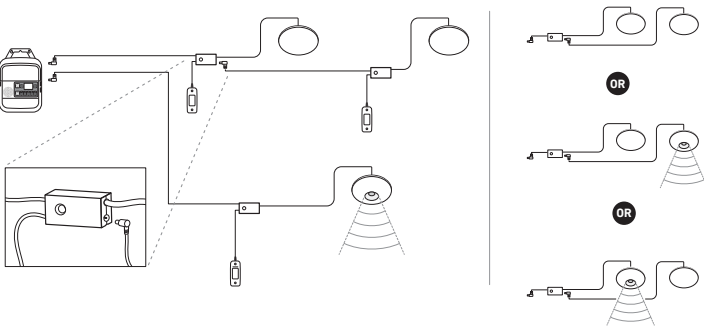

7

#### 3.3

Install **Hanging Lights** high and in center of room. Use **Hook** to secure light around beams or poles or use cord clip to secure cord to ceiling to prevent damage.

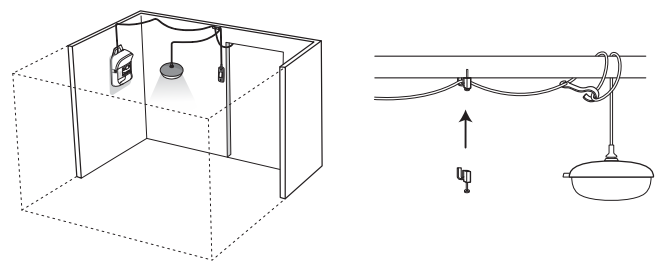

#### 3.4

Position **Light Switch** at accessible height and secure to wall with [2x] screws or nails.

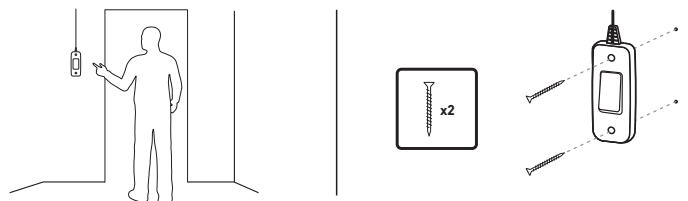

#### NOTE

Hook can also be used to angle **Hanging Light**.

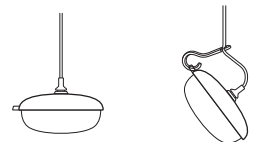

8

## 4 SECURITY LIGHT WITH MOTION SENSOR INSTALLATION

### 4.1

The **Security Light with Motion Sensor** can be set to automatically turn on. Use **Hook** to angle in the direction of where you want to detect motion of passerbys.

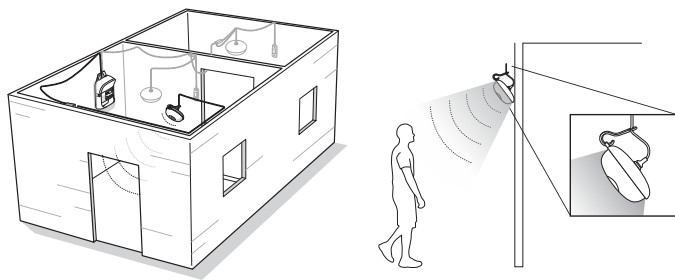

### 4.2

Secure **Light Switch** of security light on inside wall using [2x] screws or nails.

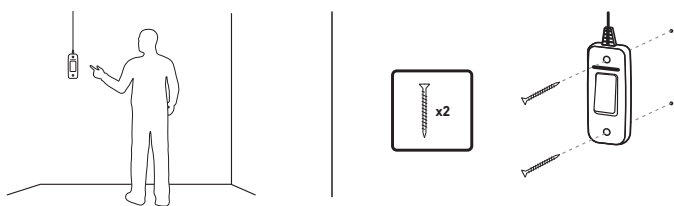

9

## 5 CONNECTING YOUR SYSTEM

### 5.1

Remove **Control Box** from wall by lifting up and away from wall screws. Connect 2 **Hanging Lights** and **Solar Panel** cords to the ports in the back of the **Control Box** as shown.

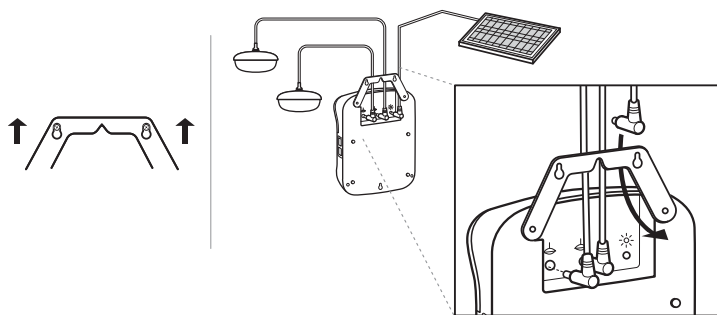

### 5.2

Return **Control Box** to secure position by sliding down over wall screws. Extend **Radio Antenna** above **Control Box** and wrap around one of the Hanging Light or Solar Panel wires to secure.

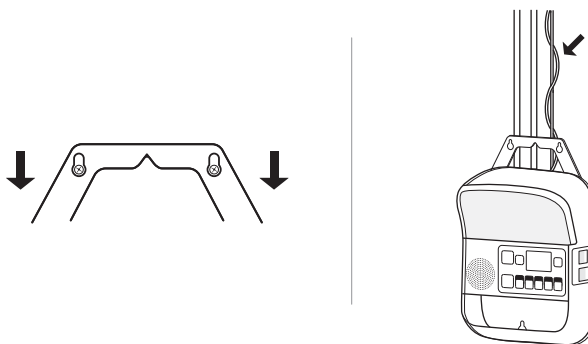

10

Congratulations!

You have completed the setup for your new SolarHome 620. The following pages will guide you on operating your system.

## GET TO KNOW YOUR CONTROL BOX

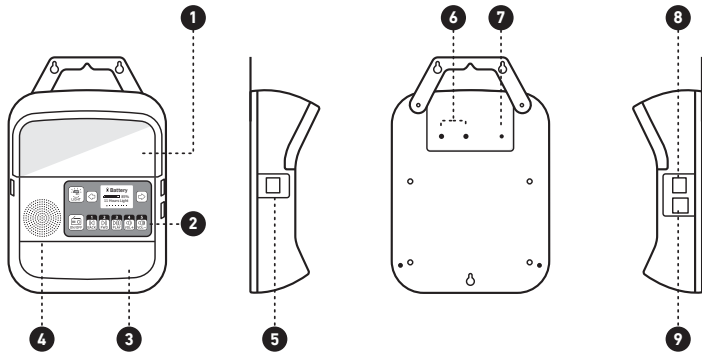

- |                  |                        |                           |
|------------------|------------------------|---------------------------|
| 1. Light         | 4. Radio/MP3 Speaker   | 7. Solar Panel Input      |
| 2. Control Panel | 5. Micro SD Card Slot  | 8. Battery Expansion Port |
| 3. Phone Storage | 6. Hanging Light Input | 9. USB Charge Out         |

## CONTROL BOX CONTROLS & SCREEN

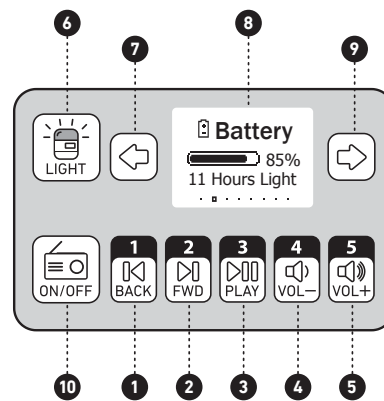

1. Radio Back
2. Radio Forward
3. Play/Pause
4. Volume Down
5. Volume Up
6. Light On/Off
7. Previous Screen
8. Display Screen
9. Next Screen
10. Radio On

The Control Box Display has eight [8] screens. Access by pressing Back [←] or Forward [→] Arrows

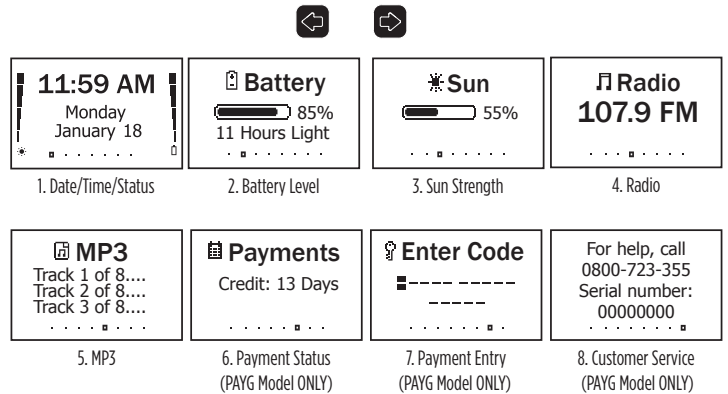

## CHARGING IN & POWER USAGE

Your system's power supply is directly affected by the strength of the sun which will vary by weather, season, and time of day. You can see **Current Sun Strength** (Screen 3) on your **Control Box Display**.

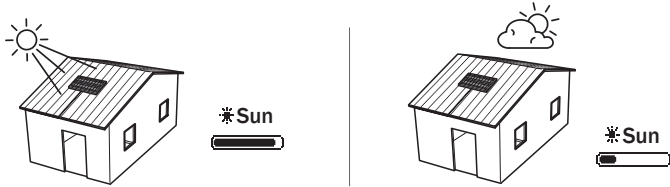

View your **Battery Level** (Screen 2) on your **Control Box Display**. It will take 4-6 hours to fully charge your system, depending on sun strength and if lights are in use.



Power from the Solar Panel is used to run your lights and the radio. You can also use this power to charge cell phones and other small electronics. Use the **USB Port** on the right side of the **Control Box** to connect your device. If control box is in sleep, press left or right arrow to wake up before charging.

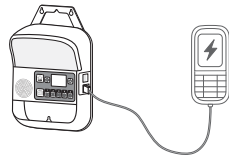

### ONE FULL DAY'S CHARGE WILL RUN:

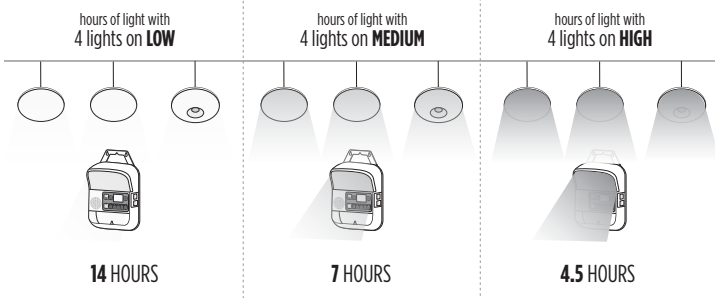

## CONTROLLING YOUR LIGHTS

The three lights and Control Box have three brightness settings: **Low**, **Medium**, and **High**. Use diagram below to access desired brightness by pressing **Light Switch** the correct number of times.

Total run time of your light depends on brightness settings, battery levels, and how many other units or features are being used at the same time.

Button Presses	1x	2x	3x	4x	5x
Battery Light	Low	Medium	High	Off	
Hanging Lights	Low	Medium	High	Off	
Hanging Lights	Low	Medium	High	Motion Sensor On	Off

The LED on the **Security Light Switch** will illuminate when Motion Sensor is active. Security Light will remain on for 30 seconds after motion is detected.

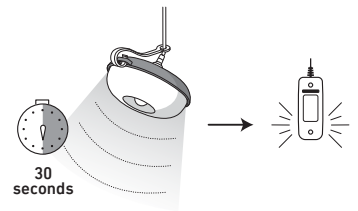



## SETTING TIME AND DATE

1. To set time, hold down the **RIGHT ARROW** until the hour position is highlighted.

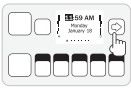

3. Use **VOL-** (4) and **VOL+** (5) to decrease or increase value.

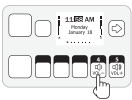

2. Use **BACK (1)** and **FWD (2)** buttons to move through hour, minute, day and date positions.

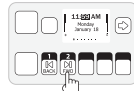

4. When finished, press **PLAY (3)** to confirm.

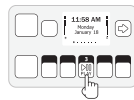

## USING THE MP3 PLAYER AND RADIO

**PLAYING MP3 FROM MICRO SD CARD**  
Insert Micro SD card into slot on left side of Control Box

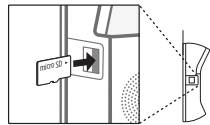

### MP3 Controls

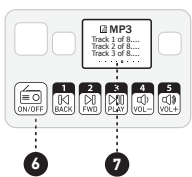

1. Previous Song
2. Next Song
3. Play/Pause
4. Volume Down
5. Volume Up
6. MP3 On/Off
7. Display

### Radio Controls

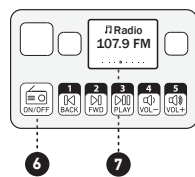

1. Station Back
2. Station Forward
3. Radio On/Off
4. Volume Down
5. Volume Up
6. Radio On/Off
7. Display

## MAKING PAYMENTS (PAYG MODEL ONLY)

### NOTE

This screen applies only if you have a pay-as-you-go plan for the purchase of your SolarHome 620.

### SEEING YOUR PAYMENT STATUS

Screen 6 shows the number of days paid for and the remaining number of days to be paid to complete ownership.

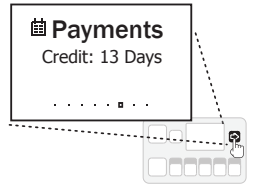

### ENTERING A PAYMENT CODE

Navigate to Screen 7. Using numbered buttons located above music controls, enter your 15-digit code. Upon submission, you will see either a **SUCCESS** message or a prompt to re-enter your code.

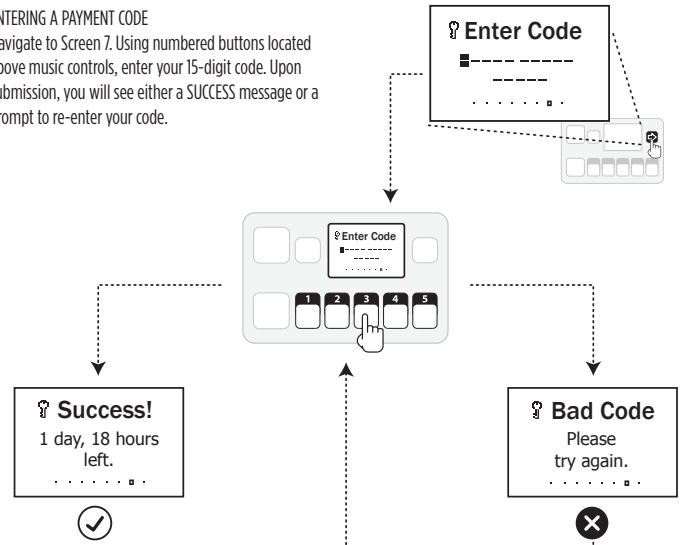









**BioLiteEnergy.com/Instructions**

**For tips, troubleshooting, tutorial videos, FAQs and more**

Manual completo de instrucciones, tutoriales en video, preguntas frecuentes y más // Manuels d'instruction complets, tutoriels vidéos, questions courantes, et bien plus // Volledige handleidingen, instructievideo's, veelgestelde vragen en nog veel meer // Vollständige Bedienungsanleitung, Tutorial-Videos, häufige Fragen und mehr // 전체 사용 설명서, 튜토리얼 동영상, 일반 질문, 기타 // Manuali di istruzioni completi, video tutorial, domande frequenti e altro ancora // 取扱説明書、チュートリアルビデオ、一般的な質問など // Täydet käyttöohjeet, ohjevideot, yleisiä kysymyksiä ja enemmän // Komplette bruksanvisning, video, vanliga frågor, och mycket mer // Full bruksanvisning, opplæringsvideoer, vanlige spørsmål og mere // 完整的说明书、视频教程、常见问题以及更多